

CUSTOM-MADE CUTTING BOARD ORDER FORM

Phone: 800-332-2500 • Fax: 800-227-1511 • Email: orders@allpointsfps.com

Instructions: This order form **MUST** be used for all custom-made cutting boards. **PLEASE FILL OUT THE EXACT SPECIFICATIONS.**
 Custom-made items are **NOT RETURNABLE.** You can fax this form or email it to **orders@allpointsfps.com.**

Shipping information (if different):

Company Name _____ Account Number _____
 Address _____
 Phone Number _____ Fax Number _____
 Email Address _____
 Authorized By _____ Purchase Order Number _____

Name _____
 Street Address _____
 City/State/Zip _____

Please Check One: Quote Order

Quoted Price _____ Quoted By (Salesperson) _____

Width _____ "

Length _____ "

Options: (Check options needed)

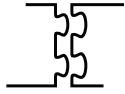
Puzzle Cut 

Cut-outs

Drill Holes— specify hole diameter; measure hole location from edges to hole center

Gravy Groove

PLEASE INDICATE SIZE AND LOCATION OF OPTIONS ON DRAWING AT RIGHT.

STANDARD CUTTING BOARDS

- Polyethylene material
- Withstands temperatures up to 165°F (74°C)
- Extreme heat may cause melting or warping
- Maximum size of 60" x 120" (1524mm x 3048mm)

White Quantity*

- _____ **No. 300-1229** ¼" (6mm) thick _____ **No. 300-1037** 1" (25mm) thick
- _____ **No. 300-1035** ½" (13mm) thick
- _____ **No. 300-1036** ¾" (19mm) thick

Black Quantity*

- _____ **No. 300-1235** ½" (13mm) thick _____ **No. 300-1100** ½" (13mm) thick
- _____ **No. 300-1236** ¾" (19mm) thick _____ **No. 300-1231** ¾" (19mm) thick

Green Quantity*

- _____ **No. 300-1101** ½" (13mm) thick _____ **No. 300-1102** ½" (13mm) thick
- _____ **No. 300-1232** ¾" (19mm) thick _____ **No. 300-1233** ¾" (19mm) thick

Brown Quantity*

- _____ **No. 300-1038** ½" (13mm) thick _____ **No. 300-1103** ½" (13mm) thick
- _____ **No. 300-1230** ¾" (19mm) thick _____ **No. 300-1234** ¾" (19mm) thick

Red Quantity*

Yellow Quantity*

Blue Quantity*

RICHLITE® HIGH TEMPERATURE CUTTING BOARDS

by The Cutting Board Company

- Ideal for prep surfaces or under heat lamps, and for equipment applications, such as steam tables, griddle stands, bread warmers, or carving tables
- Can hold hot pots, fryer baskets, and skillets while cooling
- Maximum size of 48" x 96" (1219mm x 2438mm)
- Maximum temperature rating 350°F (177°C)
- Stain-resistant and dishwasher safe
- Resin-impregnated wood fiber

Caramel Quantity*

- _____ **No. 300-1237** ¼" (6mm) thick
- _____ **No. 300-1111** ½" (13mm) thick
- _____ **No. 300-1112** ¾" (19mm) thick
- _____ **No. 300-1113** 1" (25mm) thick

Black Quantity*

- _____ **No. 300-1238** ¼" (6mm) thick
- _____ **No. 300-1239** ½" (13mm) thick

*Quantity must be filled in to place order.